

CAD FILE:

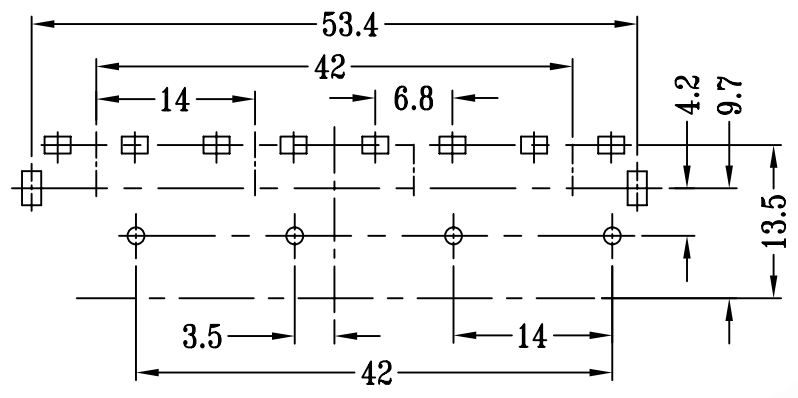

P.C.B LAYOUT

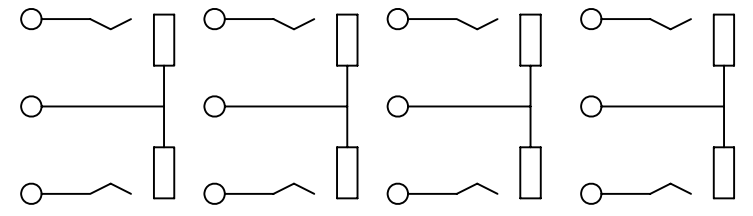

SCHEMATIC

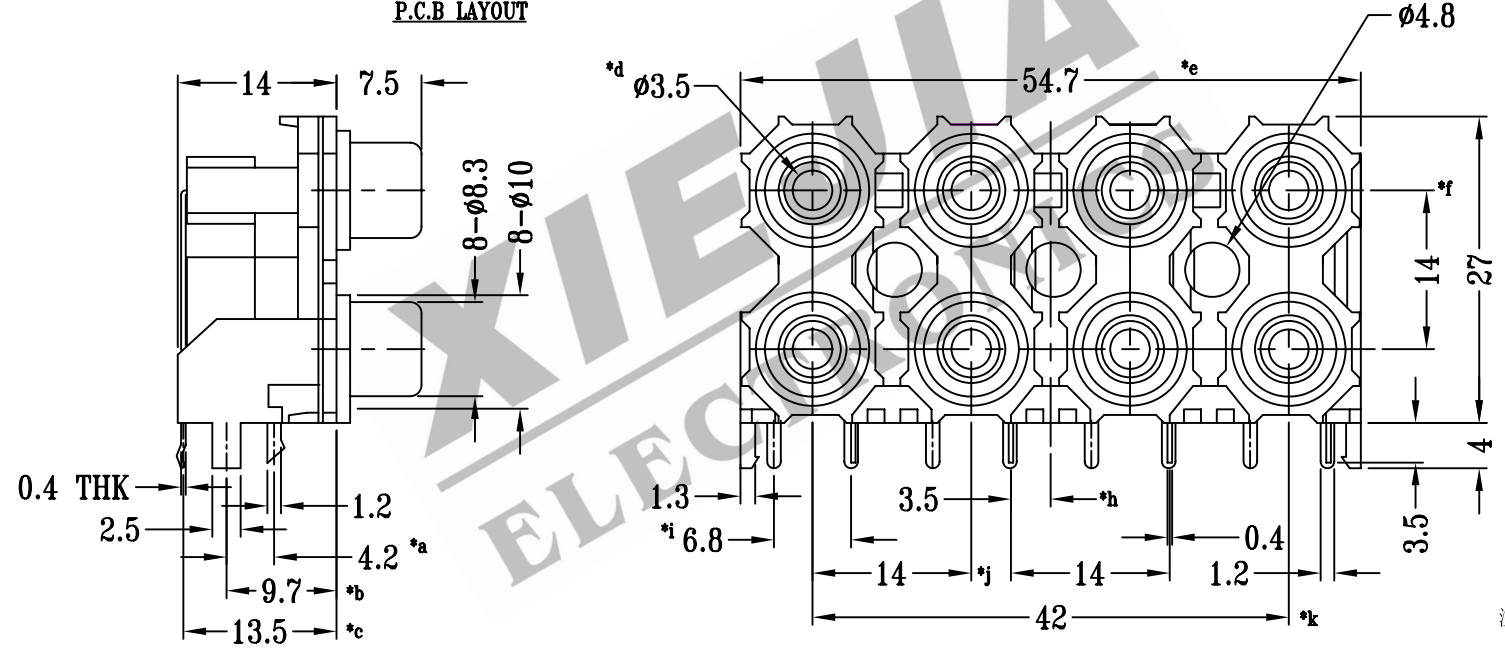

注:带"*"表示关键尺寸(11个)

8					TOLERANCE	SHENZHEN XIEJIA ELECTRONICS CO.,LTD.				
7					UNLESS SPECIFIED					
6	WASHER	ABS	8	WHITE/BLACK	WITHIN : 1.5±0.1mm	ISSUE	DATE	DESCRIPTIONS OF REVISION		APPD.
5	COVER	ABS	4	BLACK	OVER : 1.5±0.2mm					
4	TERMINAL B	BRASS STRIP	4	Ag NPLATED OVER Ni PLATED	TITLE : VERTICAL SLIDE SWITCH		UNIT : mm	DRWG NO.: XJ-DR-RC833-00		
3	TERMINAL A	BRASS STRIP	4	Ag NPLATED OVER Ni PLATED	MODEL: RC-833		SCALE: 3:2	DWN.	ZHOUYU	2005-4-8
2	CASE	ABS	1	RED	ALL MATERIALS MUST BE COMPLIANT TO ROHS			CHK'D	FANGYING	2005-4-8
1	SLEEVE	BRASS STRIP	4	Cr PLATED				APPD.	KANGXINAN	2005-4-8
NO.	PARTS	MATERIALS	Q'TY	FINISH						